

# DYNALCO

3211 Fruitland Ave  
Los Angeles, CA 90058

## UM-200

### 2-Channel Monitor

**Version 2**

## Installation and Operation Manual



**Rev. D**

P/N145F-13019

(c) Copyright 2013, Dynalco Controls

All Rights Reserved

Published: December 3, 2013

**IMPORTANT - PLEASE READ BEFORE PROCEEDING!**

This manual applies to all Version2 UM-200 monitors.

The Dynalco model UM-200 is designed for reliable and rugged operation on engines, turbines, pumps, compressors and other machinery for accurate process measurement and protection. This product has been designed and tested to meet the demands required in many industrial and hazardous locations meeting critical CSA standards. The performance is directly related to the quality of the installation and knowledge of the user in operating and maintaining the instrument. To ensure continued operation to the design specifications, personnel should read this manual thoroughly before proceeding with installation, operation and maintenance of this instrument. If this product is used in a manner not specified by Dynalco, the protection provided by it against hazards may be impaired.



- Failure to follow proper instructions may cause any one of the following situations to occur: Loss of life; personal injury; property damage; damage to this instrument; and warranty invalidation.

- For clarification of instructions in this manual or assistance with your application, contact Dynalco at (800) 368-6666 or (954) 739-4300 or send email to [customerservice@dynalco.com](mailto:customerservice@dynalco.com)

- Additional manuals and CSA certificates are available at
- Follow all warnings, cautions, and instructions marked on and supplied with the product.

- Use only qualified personnel to install, operate, program and maintain the product.
- Educate your personnel in the proper installation, operation, and maintenance of the product.

- Install equipment as specified in the installation section of this manual. Follow appropriate local and national codes. Only connect the product to power sources and end devices specified in this manual.

- Any repair is only to be performed by Dynalco using factory documented components. Tampering or unauthorized substitution of parts and procedures can affect the performance and cause unsafe operation of your process.
- All equipment doors must be closed and protective covers must be in place unless qualified personnel are performing maintenance.

- Shutdown / alarms should be tested monthly for proper operation (see page 9)
- Please see page 10 for CSA specific installation instructions.

## System Overview

The Dynalco UM-200 is capable of reading up to 2 input channels, calculating differential value and providing an alarm / shutdown output.

### Basic operation:

The UM-200 will be in “stopped” mode until a run indication is sensed. This is selectable as either a contact closure or magnetic pickup input. Once “running” mode is sensed, the UM-200 will read both inputs at a rate of 100 msec per channel. If any input crosses either an over or under threshold, the unit will invoke a flashing red LED on the front panel as well as an output trip (solid-state relay) that can be used for alarm or shutdown.

### Additional Features

- 5 - Digit Hourmeter Function (non-resettable)
- Engine RPM Display
- Fully programmable from front keypad
- Standard SAE case size fits panels with 3-3/8 inch (86 mm) opening

### Specifications

Input Types	J or K type thermocouple (ungrounded) accurate to +/- 0.2 % 4 - 20 mA 0 – 1 VDC 0 - 5 VDC 0 – 10 VDC
Digital Input	Closure to ground indicates run condition (or use pulsed input)
Pulsed Input	Magnetic pickup input for RPM display & to indicate run condition
Relay Output	Digital Output rated @ 0.15 A / 48 VDC
Input Power	10 – 36 VDC
Display	Backlit Graphic Display
Connections	Screw Terminals
Operating Temperature Range	- 40 to + 70 Deg C
Certification	CSA Class I, Division 2, Groups A, B, C, D

### User Interface

The UM-200 is configured via the keypad on the front panel which includes a graphical backlit LCD display capable of displaying alpha numeric values and custom engineering units of measure. The keypad implements a menu system, which is navigated using the up, down, left, right, enter and escape buttons. The backlight will turn off after five minutes of inactivity and will turn on when any of the keys are pressed.

## Installation

The UM-200 is designed to be panel mounted. The dimensions are shown below.

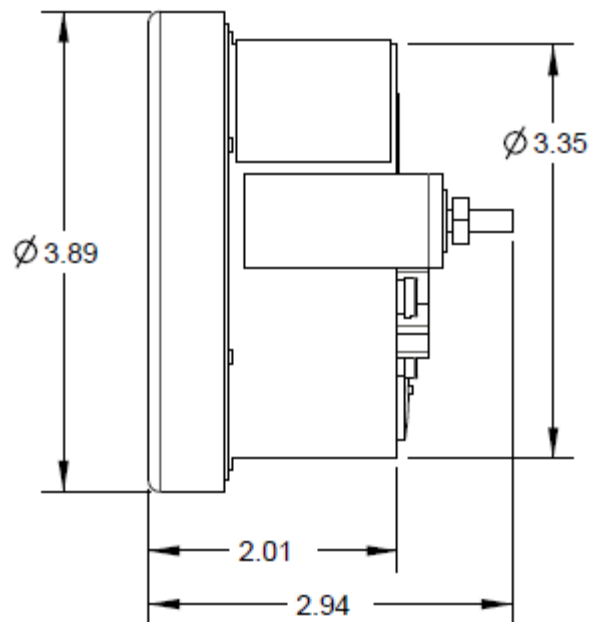

The UM-200 has a bracket for securing into the panel.



## Terminal Connections

All connections are made to terminals on the back of the unit.

SIGNAL	TERMINAL
NEG.(-) DC VOLTS	1
POS.(+) DC VOLTS	2
NEG.(-) AI CHNL 1	3
POS.(+) AI CHNL 1	4
NEG.(-) AI CHNL 2	5
POS.(+) AI CHNL2	6
RPM SIGNAL IN	A
ALARM OUTPUT (+)	B

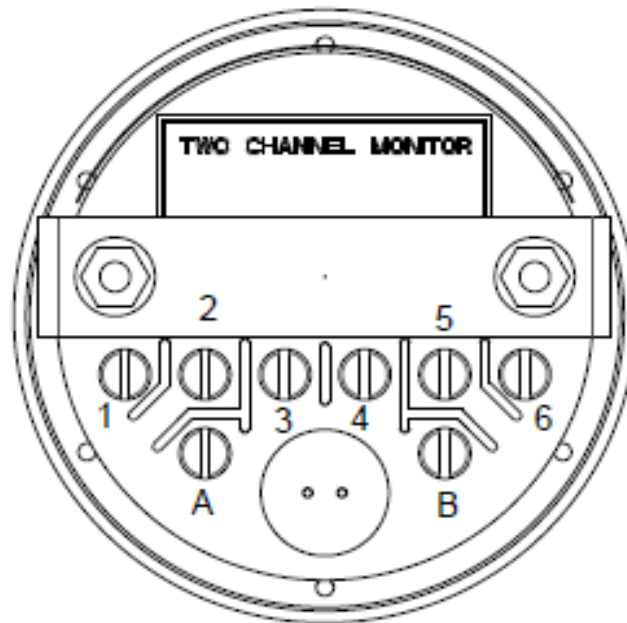

*Terminal screws to be tightened to 8 inch-pounds torque.*

*See page 10 for complete wiring information.*

## Programming Overview

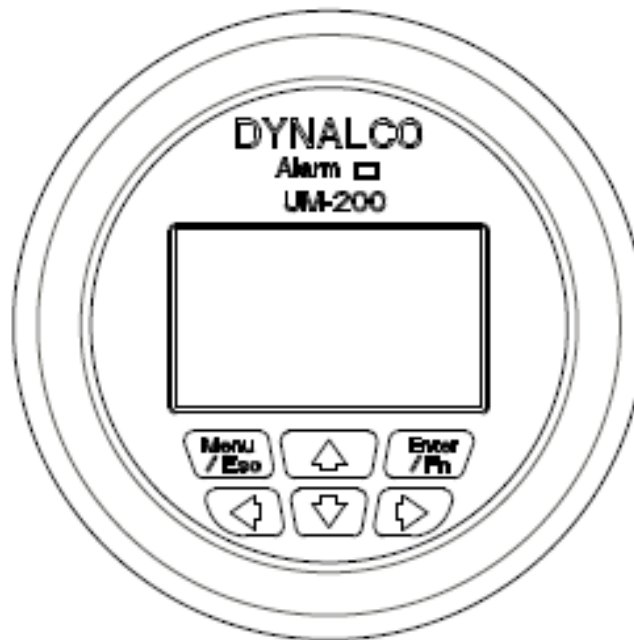

All programming is accomplished through the front keypad. Below is a brief description of each key.



Press to enter or exit the configuration screens



Press to enter or accept values



Select up



Select down



Go back one screen



Select and advance to next screen

Initial configuration consists of the following steps:

- 1) Enabling each input
- 2) Defining each input type
- 3) Defining min. & max. display values for any current or voltage inputs
- 4) Defining measurement display units (PSI, mV, F, C, H2O, etc)
- 5) Setting over / under setpoint trips
- 6) Setting either latching or non-latching for output trip

## Programming Instructions

**Important: The UM-200 must first be programmed prior to operation.**

When first powering up the unit, the display will first indicate the firmware version and then go to the operational mode.

To configure each input, first go to the main programming screen by pressing the Menu / Escape key:



The main configuration screen shows the following icons:



Run Signal

- defines run status input type



Channel

- enables each channel & defines input type



Calibration

- defines zero & span values for DCV & mA inputs



Alarm Settings

- defines alarm thresholds



System

- configures password & digital output logic

## Configuration of “Run Signal”

Using the arrows on the keypad, select the “Run Signal” icon.

There are (3) run types available. The definitions are as follows:

**None:** No run indication required. Monitoring is always active.

**RPM:** Monitoring is active when signal received from magnetic pickup.

**Digital:** Monitoring is active when contact closure (connection to ground) is sensed.

To select run signal type, use the up / down arrows to select, then press the right  arrow.

If “**None**” is selected, there is no other action required other than to select “escape.” After selecting escape, you will be asked to select “yes” to save.



If “**RPM**” is selected, you will need to set the # gear teeth, RPM threshold and startup delay. The RPM threshold is the speed above which monitoring will be active. The startup delay allows you to delay monitoring for as many as 300 seconds (5 minutes) to allow time for all inputs to be at normal levels. If no delay is required, set to 0 seconds. The magnetic pickup should be connected to input terminals (A) and (1). See page 4 for connections.

If “**Digital**” is selected, you will only need to set the startup delay (if applicable). In this mode, a run signal will be sensed with a contact closure (or short) between terminals (A) and (1).

Pressing  at any time during configuration will prompt you to save the changes. Select “Yes” to save any changes made. Selecting “No” will not save changes.

## Configuration of each “Channel”

Using the arrows on the keypad, select the “Channel” icon.

Next, select the channel number to configure by pressing the up / down arrows and press the right  arrow. Use the right  arrow to navigate and select the following:

Enable Channel	Yes / No
Channel Type	0-1 V, 0-5 V, 0-10 V, 4-20 mA, J Type, K Type
Description	name input with up to 20 characters
Engineering Units	up to 3 characters for PSI, F, C etc...

**Note:** For thermocouple inputs, you must enter either “F” or “C”

**Differential calculations** between channels 1 & 2 are also enabled by selecting the “Channel” icon.

Using the arrows on the keypad, select the "Calibration" icon. Next, select the channel number to configure by pressing the up / down arrows and press the right  arrow.

The screens allow you to define the "Cal Zero" and "Cal Span" values for a channel that is configured for 0-1 V, 0-5 V, 0-10 V or 4-20 mA input.

#### Example 1:

A pressure transmitter is connected to channel # 1. The transmitter has a 4-20 mA output representing a pressure input of 0 - 500 PSI. The "Cal Zero" and "Cal Span" values would be defined as:

Cal Zero = 0  
Cal Span = 500

Note that the "Engineering Units" would be input as PSI in "Channel" configuration above.



#### Example 2:

An oxygen sensor is connected to channel # 2. The output of the oxygen sensor is 0-1 VDC (0-1000 mV). The "Cal Zero" and "Cal Span" values would be defined as:

Cal Zero = 0  
Cal Span = 1000

Note that the "Engineering Units" would be input as mV in "Channel" configuration above.

### Configuration of "Alarm Settings"

Using the arrows on the keypad, select the "Alarm Settings" icon. Next, select the channel number to configure by pressing the up / down arrows and press the right  arrow. Use the right  arrow to navigate and select the following:

Enable alarms	Yes / No
Alarm Type	latching or non-latching
Alarm Output	select to enable output trip
Alarm Low	select threshold for under-trip
Alarm High	select threshold for over-trip
Alarm Reset Points	select either the default reset value or manually set
Alarm Reset Low	manually set reset hysteresis for low trip
Alarm Reset High	manually set reset hysteresis for high trip

## System

Using the arrows on the keypad, select the “System” icon.

“Display defaults” allows selection of two different screen displays:

“Single Channel” mode displays each individual channel in large format

“Differential” mode displays both input channels plus differential. It also displays RPM & Hours if the “Run Signal” is configured for “RPM” input.

*Note that you are selecting the default layout type. You will be able to change the layout during normal operation by pressing the left / right arrows.*

“Digital output” is used to set the digital output logic as Normally Open or Normally Closed

“Security pin” can be enabled to set up password protection.

## Operation

Once programmed, the UM-200 will begin scanning the enabled channel inputs and will initiate alarms based on over / under threshold values configured for each channel. It is not necessary to define alarm threshold values for both channels as they may be for monitoring only.

## Alarm / Shutdown Output

The UM-200 will alarm when either channel value or differential value is above or below limits as specified. Alarms can be configured as either latching or non-latching. If an alarm condition is met, the red LED on the front panel will blink and the digital output (if enabled) will trip. Non-latching alarms will reset the alarm if its value returns to normal. Latching alarms require manual resetting by pressing the “Enter” key on the keypad.



### **WARNING:**

**Terminal connection screws to be tightened to 8 inch-pounds torque.**

**The alarm / shutdown output should be tested monthly for proper operation, especially if being used for over / under pressure, over / under temperature shutdown or other critical function.**

## **Additional instructions for current users of Dynalco models TID-110 or STM-110 series temperature monitors**

The following products may be upgraded to the model UM-200 monitor:

TID110-11	J type thermocouple (displays in DegF)
TID110-12	J type thermocouple (displays in DegC)
TID110-13	K type thermocouple (displays in DegF)
TID110-14	K type thermocouple (displays in DegC)
STM110-11	J type thermocouple (displays in DegF)
STM110-12	J type thermocouple (displays in DegC)
STM110-13	K type thermocouple (displays in DegF)
STM110-14	K type thermocouple (displays in DegC)

Please see the programming steps in this manual for configuring the proper thermocouple type and display in either DegF or DegC. Replacing the STM-110 series will also require setting up the over temp alarm.

**WARNING:**

1. SUBSTITUTION OF COMPONENTS MAY IMPAIR DIVISION 2 CERTIFICATION.
2. WHEN USED IN DIVISION 2, DO NOT DISCONNECT UNLESS POWER HAS BEEN SWITCHED OFF OR THE AREA IS KNOWN TO BE NON-HAZARDOUS
3. MAXIMUM AMBIENT TEMPERATURE +70 C (+158 F).

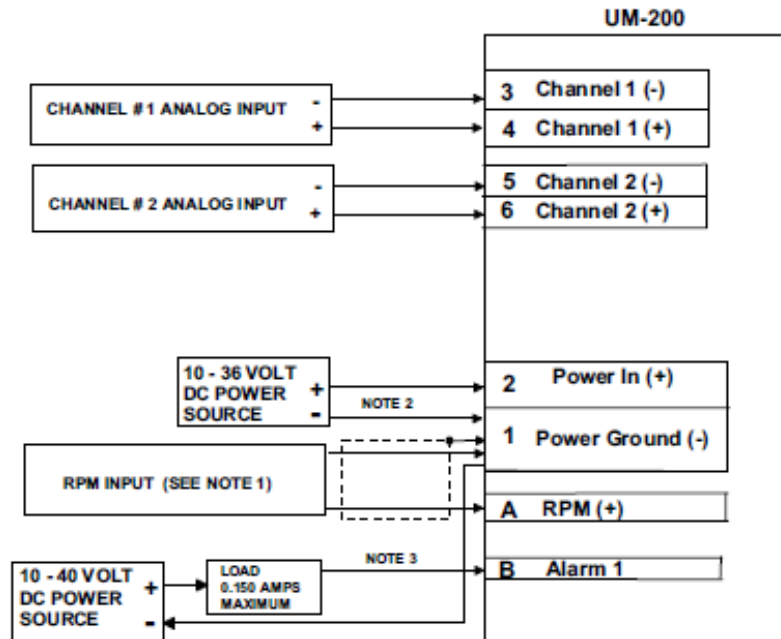
**NOTES:**

1. The M201, M202, M231, M233, M928, and M928-24 Magnetic Pickups have been approved to be connected to the RPM Input. The pickup must be connected with shielded cable with the shield connected to terminal 2 as shown. As an alternative, a contact closure may be connected to the RPM input as a "RUN" signal.
2. The unit is powered by 10 - 36 Volt DC at 0.1 Amp max.  
DC power wiring must be run in CSA approved solid or flexible conduit.
3. The Alarm output may be connected to a load not to exceed 40 Volt DC and 0.15 Amps.  
Alarm output wiring must be run in CSA approved solid or flexible conduit.
4. The UM-200 is certified for mounting in a suitable enclosure. Suitability of the final combination is to be determined by CSA or the inspection authority having jurisdiction.

N:\PRODUCTS\UM-2\CSA\UM-200 Interconnect.dxf

THIS DOCUMENT, ALL INFORMATION CONTAINED HEREIN AND ALL INFORMATION RELATED THERETO, IS THE PROPERTY OF DYNALCO CONTROLS (A CRANE COMPANY) IS CONFIDENTIAL TO IT AND NO PART THEREOF, NOR ANY SUCH INFORMATION MAY BE COPIED, DISSEMINATED OR USED IN SUCH A MANNER WITHOUT THE WRITTEN CONSENT OF DYNALCO AND IS TO BE RETURNED TO DYNALCO UPON REQUEST.

**DO NOT SCALE THIS DRAWING****REVISIONS**

LTR	DESCRIPTION	DATE	APPD

Wiring diagrams below are shown for Channel #1. Channels 2 will be wired in a similar manner.

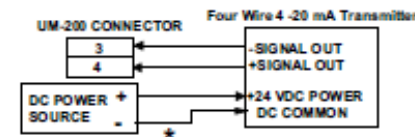
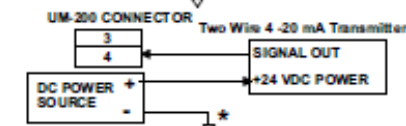
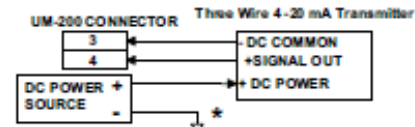
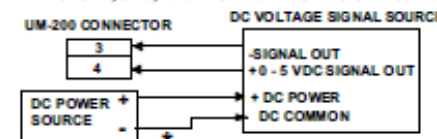
**WIRING 4-20 mA TRANSMITTERS TO UM-200 CHANNEL # 1****WIRING 0 - 1, 0 - 5, or 0 - 10 VDC INPUT TO UM-200 CHANNEL # 1**

\* 0 - 1, 0 - 5, 0 - 10 VDC and 4/20 Milliamp Transmitters must be powered by a power supply which has the same common (-) as the power to the UM-200 Monitor.

4/20 Milliamp and 0 - 5 Volt Transmitters connected to the UM-200 Monitor must be approved for use in Class I, Division 2, Groups A, B, C, & D areas.

Any ungrounded thermocouple may be connected to the UM-200 Monitor as the thermocouple input circuit has been evaluated as non-incendive.

**THE UM-200 MONITOR IS CSA APPROVED FOR USE IN CLASS I, DIVISION 2, GROUP A, B, C, & D LOCATIONS WHEN INSTALLED PER INSTRUCTIONS ON THIS DRAWING.**

UNLESS OTHERWISE SPECIFIED DIMENSIONS ARE IN INCHES AND TOLERANCES ARE:

FRACT.	DEC.	ANGLES
1/64	.005	± 1/2
XX	± .01	DIGITS

MATERIAL:

FINISH:

**DYNALCO CONTROLS** FT. LAUDERDALE, FL., USA

PRODUCT PART	UM-200	DRAWN BY	D. A. Weaver	DATE	01/13/11
APPROVED					

TITLE: **INTERCONNECTION DRAWING**  
**CSA APPROVED UNITS**

SCALE	SIZE	DRAWING NUMBER	PAGE	OF	REVISED
	<b>A</b>	<b>80012971</b>	1	1	-